

800/900 Series Linear Heat Detectors



Models Available

JTW-LD-70-887

JTW-LD-85-887

JTW-LD-85/105-889

JTW-LD-997

Features and Specifications

800/900 Series Linear Heat Detector is designed to use in the cable fields where the environment is relative better and other dangerous environments, such as the electric power distribution system, industry process and the material conveyor systems, stock room , the petrolic reservoir zones and so on .

JTW-LD-70-887 JTW-LD-85-887 JTW-LD-85/105-889

- Two level and multilevel alarms for the same and different temperature grades , which can greatly reduce the fault alarm rate
- Strong capability to withstand the mechanical damage , tensile , water and corrosion and electromagnetism interference with the metal matted housing and coat
- Large protection range of , the detector can lay about 3 – 500m length itself
Effectively monitor the transducer cable fault and the alarm signal utilizing the special microcomputer modulator with 1 – 4 loops
- Attachment parts for 887/M and 889/M cable box
- Compatible with any company control panel

JTW-LD-997

- Discretionarily set the alarm temperature from 70°C to 180°C , and the tolerance is not exceeded $\pm 4\%$
- Reusable transducer cable
- Capability of the temperature compensatory and can increase the no action temperature range to greatly reduce the fault alarm rate
The multilevel alarms for one loop transducer cable and monitors the short and broken circuit faults, and the temperature change trend
- Strong capability to withstand the mechanical damage, tensile, water and corrosion and electromagnetism interference with the metal shield housing and coat
- Compatible with any company control panel and the temperature monitor system

800 Series Linear Heat Detectors Wiring diagram

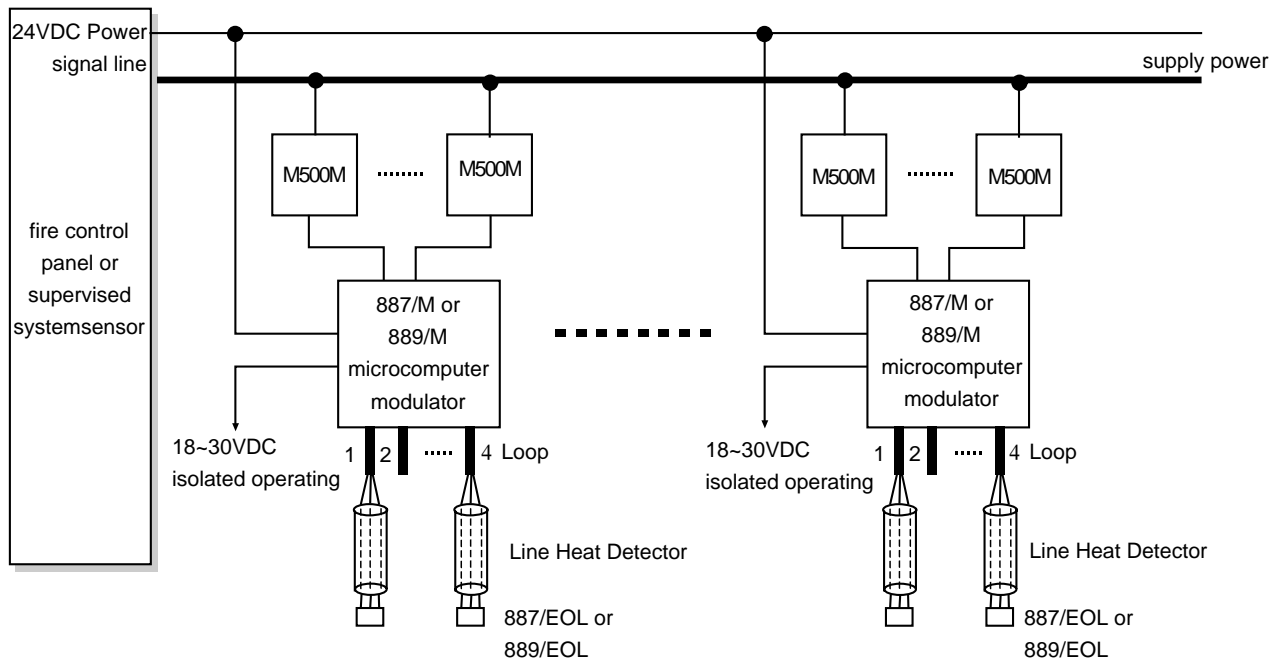

900 Series Linear Heat Detectors Wiring diagram

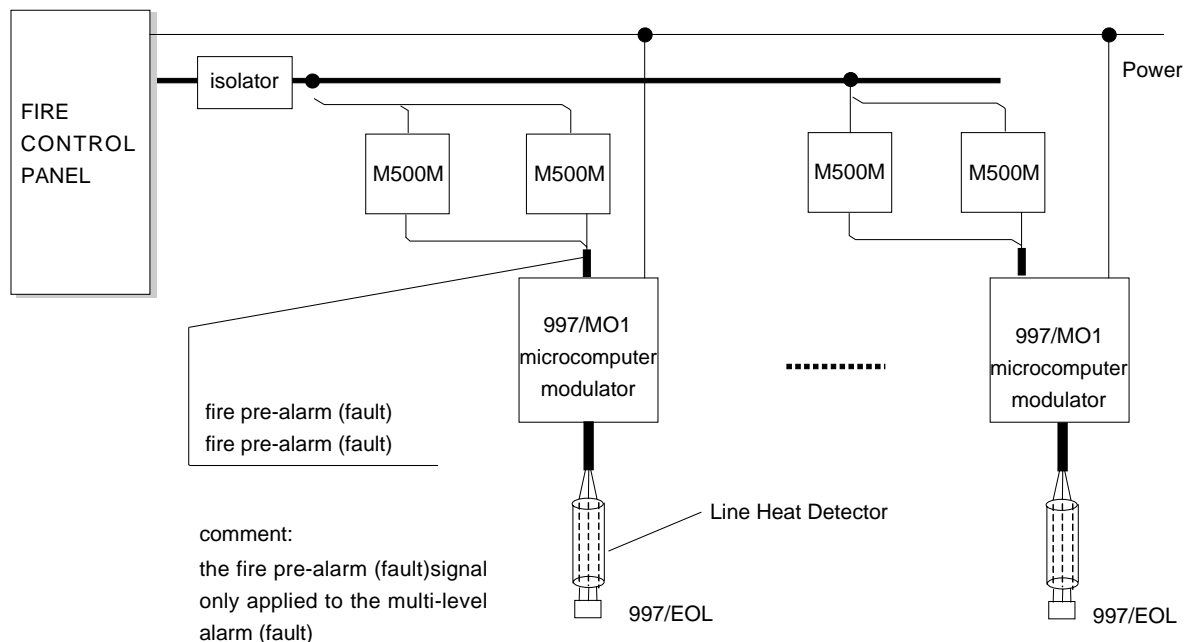

System Sensor Worldwide Manufacturing & Distribution

System Sensor Headquarters
3825 Ohio Avenue
St. Charles, IL 60174
Ph: 800-SENSOR2
Fx: 630/377-6495
Documents on Demand:
1-800-736-7672 x 3
Web: www.systemsensor.com

System Sensor - China
28 Tuan Jie South Road, Xi'an National
Hi-tech Industrial Development Zone,
Province of Shaanxi, 710075, CHINA
Ph: ++ 86.29.8832.0119
Sales Ph: ++ 86.29.8833.2810 8833.2827
Fx: ++ 86.29.8832.5110 8833.2959
Web: www.systemsensor.com.cn
E-mail: sales@systemsensor.com.cn

System Sensor - Canada
Ph: ++ 1.905.812.0767
Fx: ++ 1.905.812.0771

System Sensor - Singapore
Ph: ++ 65.273.2230
Fx: ++ 65.273.2610

System Sensor - Australia
Ph: ++ 613.54.281.142
Fx: ++ 613.54.281.172

System Sensor - Far East
Ph: ++ 852.2191.9003
Fx: ++ 852.2736.6580

System Sensor - Europe
Ph: ++ 44.1403.276500
Fx: ++ 44.1403.276501

System Sensor - India
Ph: ++ 91.124.637.1770 Extn 2700
Fx: ++ 91.124.637.3118