

SPARK DETECTOR RIV-601/S

DESE



Description

Spark detector RIV-601/S is an electronic fire alarm device, sensitive to sparks and incandescent bodies in movement. Its use is particularly recommended on dust collection systems in factories where wood is processed, chipboard or furniture are manufactured, in sawmills and the like, where fires are both probable and frequent.

It is also recommended for the textile industry, especially in cotton mills, in cereal and animal feed mills and storage and in the treatment of hides and leather. And many many others where sparks are produced and they can start a fire.

Spark detector RIV-601/S contains an element sensitive to the infrared (IR) radiation emitted by incandescent bodies, a series of amplifier and time circuits, and an output relay that provides a 2A 250VAC changeover contact.

When a spark is detected the relay is operated for 3 seconds (time can be adjusted from 1 to 10 seconds). If the sparks are continuous the relay is operated till 3 seconds after last spark.

The spark detector is designed for installation over the ducts of the dust extraction systems or pneumatic chip conveyors, so that it can see inside the duct through a window. It can also be installed over screw and belt conveyors or other mechanical systems for conveying chips, sawdust, cereals or animal feed, but sun light or artificial light must not fall directly on the detection window as they might cause false alarms.

The detector is normally installed using the SAM-870 mounting frame, in which it is supported by rubber cushions and is protected from the environment and vibrations.

SPARK DETECTOR RIV-601/S

The simplest application of the detector is to activate a sound alarm and possibly automatic plant mechanisms (stop, reverse direction etc.). More usually, however, it is combined with an automatic extinguishing system, comprising a solenoid valve and one or more water spray nozzles to extinguish every spark that runs in front of the detector with a short spray of water.

In this case the spray nozzle is installed about 15 meters downstream from the detector in order to catch the sparks travelling at 30 m/s, since a delay of 0.2 sec is assumed, due to the water flow before and after the nozzle.

Another detector may be installed downstream from the nozzle to detect any spark remaining alive due to faults in the extinguishing system (lack of water, valve blocked etc.) or large size of the fire.

A pressure switch may be fitted before the nozzle to monitor the water spray flow.

An interesting feature of the detector is its self test system. A special incandescent bulb is incorporated into the detector near the sensor. When this bulb is powered with a 24Vdc pulse it generates an infrared (IR) flash that is seen by the detector as a spark. This device allows a remote checking of the detector and the automatic extinguishing system.

Characteristics

Cast aluminum case. Protection IP66 (dust and water spray).
 Power supply 24Vdc (20-30V) filtered (ripple less than 5%).
 Current consumption 13mA normal, 50 mA in alarm.
 Spectral sensitivity infrared (IR) 1-3 micron.
 Field of view 90° cone.

Typical sensitivity: 1 mm spark at half a meter distance.
 The minimum size detected increases or decreases linearly with distance (2 mm spark at one meter, etc.).

Immediate response time (20-30ms).

Alarm time duration 3 sec (standard time). Internally adjustable from 1 to 10 sec.

Internal LED indicator showing relay alarm status.

Output changeover contact rated 2A 250VAC. Relay is active when a spark is detected, and is held active for at least 3 sec.

"Teletest" feature for remote testing of the detector.

Requires a 24Vdc 20 mA pulse to simulate a spark and cause the detector to operate.

Electrical wiring on 8 way terminal block (wire 0.5 + 1 mm²).

Operating temperature -20 +60 °C.

Storage temperature -40 +85 °C.

Relative humidity max 95% non condensing.

Cast aluminum case. IP66 protection (waterproof).

Dimensions 180x92xH80 mm.

Weight 600 g.

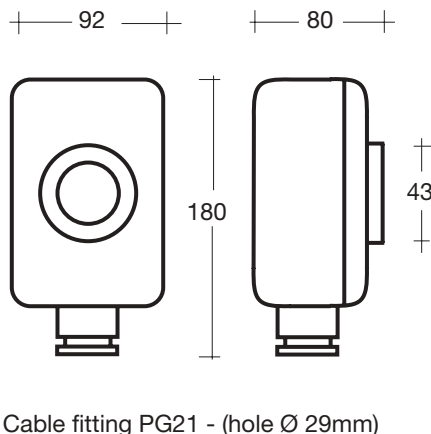

dimensions in mm

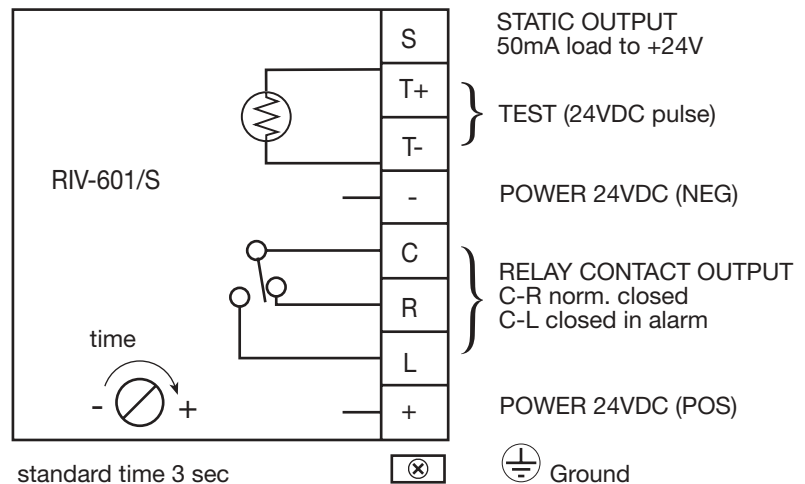

Notes:

- It is highly recommended to connect the enclosure body to a good **ground** line using the ground terminals provided inside and signaled by ground label . The ground connection must be made using a yellow-green conductor and a M4 double crimp eyelet. The yellow-green ground conductor must be longer than the other conductors.
- During wiring, 230V conductors must be kept separate from 24Vdc conductors using proper clips.
- In order to ensure an **IP66 protection grade** the cover must be tightly closed turning the four screws provided, paying attention that the rubber gasket be well positioned. The suggested closing torque value is at least 1,2Nm.